

MA SERIES



- Coaxial active horn technology
- Passive Two way system
- Single point source
- Conical 60° waveguide
- Natural sound reproduction
- MVC™ Bass-reflex cooling
- Full power handling with low thermal compression
- Suitable for medium-power FOH and side fill applications
- Designed for high performance fixed installation and touring or stage monitoring
- OEM factory presets for approved digital processors

FEATURES

The Lotusline MA15/60 loudspeaker enclosures provide a versatile system that is designed for high quality distributed sound reinforcement or high performance monitoring. Using true point source coaxial technology, the Lotusline MA series features advanced components in a flexible, multipurpose format that is suitable for either touring or fixed installation.

The MA15/60 is a passive two-way loudspeaker. The low/mid section comprises a 15 inch neodymium bass driver loaded in a 4th order MVC™ enclosure. The hi section includes a 1.4 inch neodymium High Frequency compression driver assembled in a coaxial configuration along with the full low section loudspeaker providing a conical opening.

Further advantages of the coaxial approach include: single point source radiation, total wavefront coherency at all frequencies and superimposed LF/HF dispersion characteristics that are free of polar lobbing effects typical of traditional horn and woofer combinations. The net result is natural, studio monitor level sound quality that is ideal for proximity use.

The MA15/60 provides a very coherent acoustic field with 60° conical coverage.

The new MVC™, Multi Vent Convection technology, allows the Lotusline MA series to handle nominal full power capacity in any working position.

The enclosure comprises two angles side, 45° and 60° for stage monitor application and include two 35mm built in stand supports as well as four wood integrated handles and 5 cargo standard rigging points.

The Lotusline MA15/60 crossovers are built with air core inductors, MKP capacitors and wirewound resistors.

The Lotusline MA15/60 apply full power handling with low thermal compression.

APPLICATIONS

The Lotusline MA15/60 is passive two-way loudspeaker enclosure containing a HF driver assembled in a coaxial configuration along with a full range loudspeaker providing a conical opening. Medium power touring, installed PA for A/V, broadcast, high quality stage monitoring, etc. are the application field of MA15/60.

The great additional options for the MA15/60 provide this speaker a simple and easy installation: one can put it on the floor, install it on a stand or fly it. Walls and ceilings are in its range of installation thanks to its optional lyre brackets and multiple standard fixing points.

As a main F.O.H the MA15/60 is meant for vocal applications, stage monitoring or distributed sound.

For music requirement, a dedicated setup for digital optional processor is provided in order to optimise the speaker response.

Combined with Lotusline subwoofers, the MA15/60 allows to create compact and powerful systems suitable for all indoor or outdoor configuration.

The MA15/60 is also ideal for distributed sound reinforcement and can be used in medium power front-of-house (FOH) applications for theatres, clubs, multi-purpose venues or corporate events.

FEATURES	Low Section	High Section
Frequency range with processor ($\pm 3\text{dB}$)	55 Hz to 1100 Hz	1100 Hz to 18 kHz
Frequency range without processor ($\pm 3\text{dB}$)	65 Hz to 1100 Hz	1100 Hz to 18 kHz
Sensitivity@1W/1m, f>80Hz ¹	100 dB SPL	
Maximum continuous level at 1m, f>80Hz ²	127 dB SPL	
Peak level at 1m, f>65Hz	133 dB SPL	
Nominal directivity @ -6dB ³	60° conical	
Nominal impedance	8 Ohms	

COMPONENTS

Transducers	1 x 15" weatherproof loudspeaker 1 x 1.4" HF drive coaxially mounted	
Coil diameter	75 mm	45 mm
Type of load	MVC™ Bass reflex	Conical Horn

POWER

Recommended amps	300 to 800W into 8 Ohms
Peak	2000W
AES	500W

CONSTRUCTION AND CHARACTERISTICS

Cabinet	18mm birch plywood with internal reinforcements	
Crossover	Air core inductors, MKP capacitors, wirewound resistors.	
Finish	Black, impact resistant structured and water paint coating	
Protection grill	Acoustically transparent perforated steel, 1.8mm thick	
Front face	Black, woven, heavy duty fabric	
Connectors	4 x Neutrik Speakon NL4MP	
Handles	4 wood integrated handles	
Mounting on stand and bracket	2 x 35mm built in stand fitting	
Rigging	4 inserts for Omnimount 60 series, 5 standard cargo points	
Dimensions (H x W x D)	680 x 452 x 397 mm	
Net unit weight	24.1 kg	53.1 lb
Gross weight, packed	27.2 kg	58.9 lb

CAD Drawings

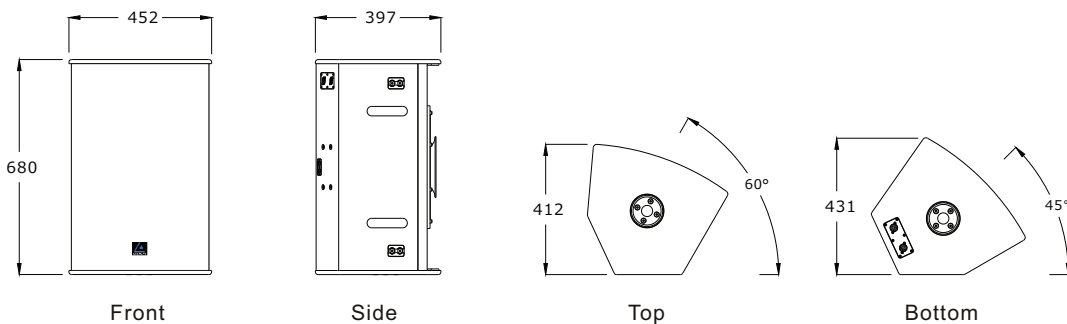

1. Sensitivity is the average SPL measured over the component's rated bandwidth
2. Power rating displays the long term AES power handling capacity using pink noise with a 6 dB crest factor over the component's rated bandwidth
3. Directivity is averaged over the 800Hz-20 kHz range.
4. The SPEAKON cables are wired, hot pin 2+, cold pin 2-.

LIMITED WARRANTY

Lotusline loudspeakers and electronics are covered against defects in workmanship or materials for a period of two (2) years from the original date of purchase. At the option of Lotusline, the defective item will be repaired/replaced with no charge for materials/labor. The item is to be adequately packaged and dispatched, pre-paid, to a Lotusline authorized distributor/service center. Unauthorized repair shall void the warranty. This Lotusline warranty does not cover cosmetics or finish and does not apply to any items which in Lotusline's opinion have failed due to user abuse, accidents, modifications or any type of misuse.



**LOTUSLINE
ACOUSTICS**